

Development of hardware for digital control system of pulsed NQR spectrometer

Igor Safronov
Master of Radio Engineering
Yuriy Fedkovych Chernivtsi National
University
Chernivtsi, Ukraine
igor130298@gmail.com

Taras Kazemirskiy
PhD of Physical and Mathematical
Science
Yuriy Fedkovych Chernivtsi National
University
Chernivtsi, Ukraine
t.kazemirskyy@chnu.edu.ua

Andrii Samila
Vice Rector for Scientific Research
Doctor of Engineering Science
Professor
Yuriy Fedkovych Chernivtsi National
University
Chernivtsi, Ukraine
a.samila@chnu.edu.ua

Abstract—The analysis is carried out and the choice of the optimal type of PLD for the implementation of a digital control system for a pulsed coherent NQR spectrometer is proposed. Structural and functional synthesis of electronic devices based on FPGA EP1C6T144C8N has been carried out. The development can also be used in the study of the operation of programmable logic integrated circuits for deepening knowledge and skills in the languages for describing equipment for modeling electronic systems – Verilog HDL, VHDL.

Keywords— *programmable logic devices, FPGA, hardware, radiospectrometer, NQR*

I. INTRODUCTION

The development of a wide range of radiospectroscopic methods for scientific research of nuclear resonance phenomena in semiconductors, defects and impurities in vertical multilayer semiconductor structures has led to the development of high-precision measuring devices for electron paramagnetic (EPR), nuclear magnetic (NMR) and quadrupole (NQR) resonances [1]. The NQR spectrometry technique provides for the need to register weak free induction decay (FID) signals with their subsequent complex mathematical processing in real time. Modern stationary type spectrometers, despite their high sensitivity and functionality, have significant weight and size, high cost and at the same time require special training and education of service personnel. The presence of a large number of settings and controls, to some extent, complicates the work of untrained scientists and researchers [2].

The paper describes the development of hardware for a digital control system for a pulsed coherent NQR spectrometer in the form of a unified module based on an EP1C6T144C8N programmable logic device (PLD). The use of PLD simplifies and reduces the cost of production and operational characteristics of the finished complex as a whole.

II. ANALYSIS OF EXISTING SOLUTIONS

A. Classification of PLD

PLD is a new element base that combines the flexibility of special purpose large-scale integrated circuits and the availability of traditional hardware logic. The main advantage of PLDs is the ability to configure them to perform specified functions by the user himself. Prospects for the development of electronic equipment based on widely available and at the same time productive PLDs provide an opportunity to master design skills on their basis for various functional elements of digital circuitry - from simple elements of combinational and sequential logic to complex microprocessor systems.

At the present stage of development of integrated

electronics, there are various types of PLDs, both in terms of architecture and the type of configuration change [3]. To change the operation algorithm of PLD-based radio electronic devices, a simple change in their configuration structure is sufficient. In addition, most PLDs can be programmed (reprogrammed) after the integrated circuit is mounted on the board. In fact, the development of PLD-based devices is based on a new technology for the design of electronic circuits, including their fabrication and setting.

The diagram shown in Fig. 1 visualizes a tree of the PLD family and their main types.

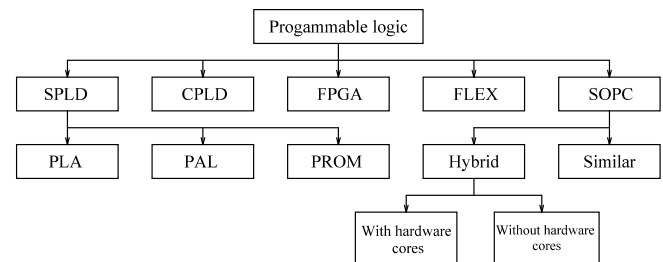

Fig. 1. PLD family

B. The main advantages of PLD

Typical applications of PLD: digital signal processing, data acquisition systems, control systems, telecommunications equipment, equipment for wireless communication systems, general purpose computer equipment. Unlike microprocessors, PLD can organize FID digital signal processing algorithms at the hardware (schematic) level. At the same time, the digital processing speed increases dramatically. The advantages of implementing a PLD-based NQR spectrometer control system are:

- minimum time to develop the configuration structure (you only need to enter the configuration code in the PLD memory);
- in contrast to the usual elements of digital circuitry, the use of PLD eliminates the need to develop and manufacture complex printed circuit boards;
- fast conversion of one configuration to another (replacement of the configuration code of the integrated circuit in memory);
- reduction in cost and weight and dimensions. To create a device, there is no need for complex technological production.

III. STRUCTURAL AND FUNCTIONAL SYNTHESIS OF HARDWARE

A. Choice of PLD integrated circuit

Optimal in terms of price-quality ratio and the most

available in the market of electronic components are complex programmable logic device (CPLD) and field-programmable gate array (FPGA) of Intel. The following families are represented on the market from Intel: Max, Cyclone, Aria, Stratix, Agilix. The first integrated circuits of the Cyclone family appeared in 2002. Since then, several families have been released and today Intel Corporation produces integrated circuits of the Cyclone V family.

For development we have chosen FPGA Altera Cyclone [4]. The main element of FPGA is a configurable logic block (CLB), which includes elementary cells - logical cells (LC). The array of logical blocks contains columns of memory blocks and multipliers. Input/output elements (IOE) are used to exchange information between the integrated circuit and peripherals. On two mutually opposite sides of the crystal, there are two functionally independent phase-locked loop (PLL) blocks that can be configured in software. In addition, there are configuration nodes and configuration memory on the integrated circuit chip that are inaccessible to the user. The resource list of some Cyclone family chips is given in Table 1.

TABLE I. PARAMETERS OF CYCLONE FAMILY CHIPS

Parameter	EP1C3	EP1C6	EP1C20
Number of logical elements	2910	5980	20060
Number of M4K memory blocks (128×36 bit)	13	20	64
Total memory, bit	59904	92160	294912
PLL blocks	1	2	2
Ports available to the user	104	185	301

FPGA EP1C6T144C8N was chosen as the basis for the development of hardware for the digital control system of the pulsed NQR spectrometer. The internal structure of this FPGA contains about 6000 logical elements that allow the implementation of digital function blocks through software configuration. The basis of the logical element of this FPGA, the architecture of which is shown in Fig. 2, there is a look-up table. The selected integrated circuit allows the use of external RAM (DDR SDRAM, SDR SDRAM, FCRAM). Input-output of digital data is carried out through 185 ports with an arbitrary configuration and support for operation at frequencies up to 304 MHz, which is enough to implement a digital control system for an NQR radio spectrometer.

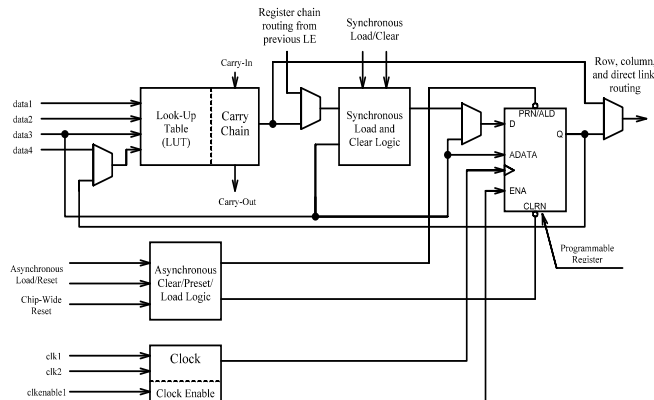

Fig. 2. Altera Cyclone FPGA logic element architecture

B. Design of the NQR spectrometer control system

The design of the digital control system for the NQR spectrometer included the following stages:

- analysis of the operating mode of the input-output ports of the FPGA integrated circuit in order to ensure the implementation of the maximum possible number of peripheral devices;
- development of a configuration device for loading the FPGA configuration program by means of universal programmers;
- design of the power supply system for all functional units of the device;
- development of general structural and electrical schematic diagrams of the device.

FPGA's ability to work simultaneously with several I/O standards simultaneously allowed us to use peripheral devices with different I/O standards in our development (Fig. 3). In most cases, peripheral devices based on integrated circuits work with signals up to 3.3 V. To work with TTL and CMOS logic signals with a supply voltage of 5 V, level converters must be used.

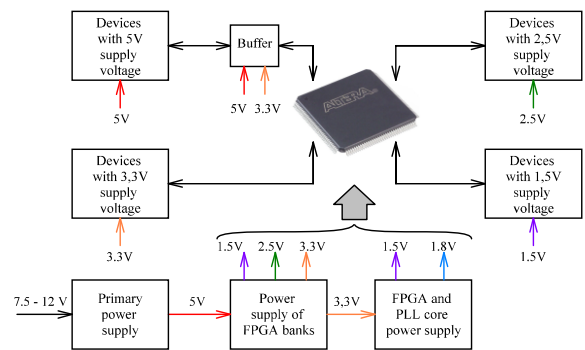

Fig. 3. Operation of the EP1C6T144C8N chip with different I/O standards

The main types of peripheral devices (Fig. 4) are selected taking into account the possibility of providing a wide range of functional capabilities of the NQR spectrometer control system. The development provides for the ability to display graphic images on a TFT LCD. For storing raster graphics data of the video subsystem, an external read-only memory integrated circuit is provided. In addition, the proposed device provides for the possibility of data transmission via the RS-232 serial interface. The user interface also contains controls in the form of a keyboard and indication – LEDs. Providing support for multiple standards for different peripherals is achieved thanks to the architecture applied by FPGA and separate power lines for different banks (Fig. 5).

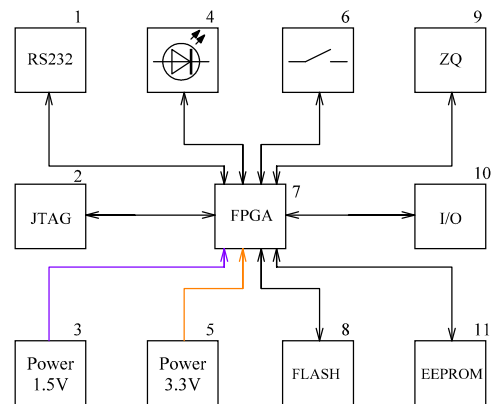

Fig. 4. Structural diagram of the developed device: 1 – RS-232 interface; 2 – built-in and external programming interface; 3 – 1.5 V power supply; 4 – indication LEDs; 5 – 3.3 V power supply; 6 – buttons; 7 – programmable logic interface; 8 – flash memory; 9 – quartz resonator; 10 – motherboard with I/O ports; 11 – flash memory for storing the program code.

C. Circuit diagram

The electrical circuit diagram of the digital control system NQR spectrometer is shown in Fig. 5. The hardware of this system is built on the basis of FPGA EPIC6T144C8N (U1), which, for convenience, is depicted in the schematic diagram in the form of individual blocks. To power the FPGA, two voltage regulators are used: 3.3 V – powering the banks of the I/O ports, 1.5 V – powering the core. Light indication D1 indicates the presence of power supply to the core. The choice of the configuration mode is determined by the combination of logic levels at the MSEL U1 inputs. Programming is carried

out using the JTAG protocol. EEPROM (U6) is used to store configuration firmware. Flash-memory S29GL064N (U5), connected by means of a parallel interface, is required to store graphic files of the video subsystem. The clock frequency can be set by two separate thermo-stabilized crystal oscillators. One (generation frequency 33.333 MHz) is located directly on the board of the developed device, the other is on the motherboard of the spectrometer. The MAX3232 (U4) integrated circuit is designed to match the logic signal levels of the RS-232 serial interface with the TTL logic levels. Connection of the developed device to the motherboard of the NQR spectrometer is provided using 144 PLS pins.

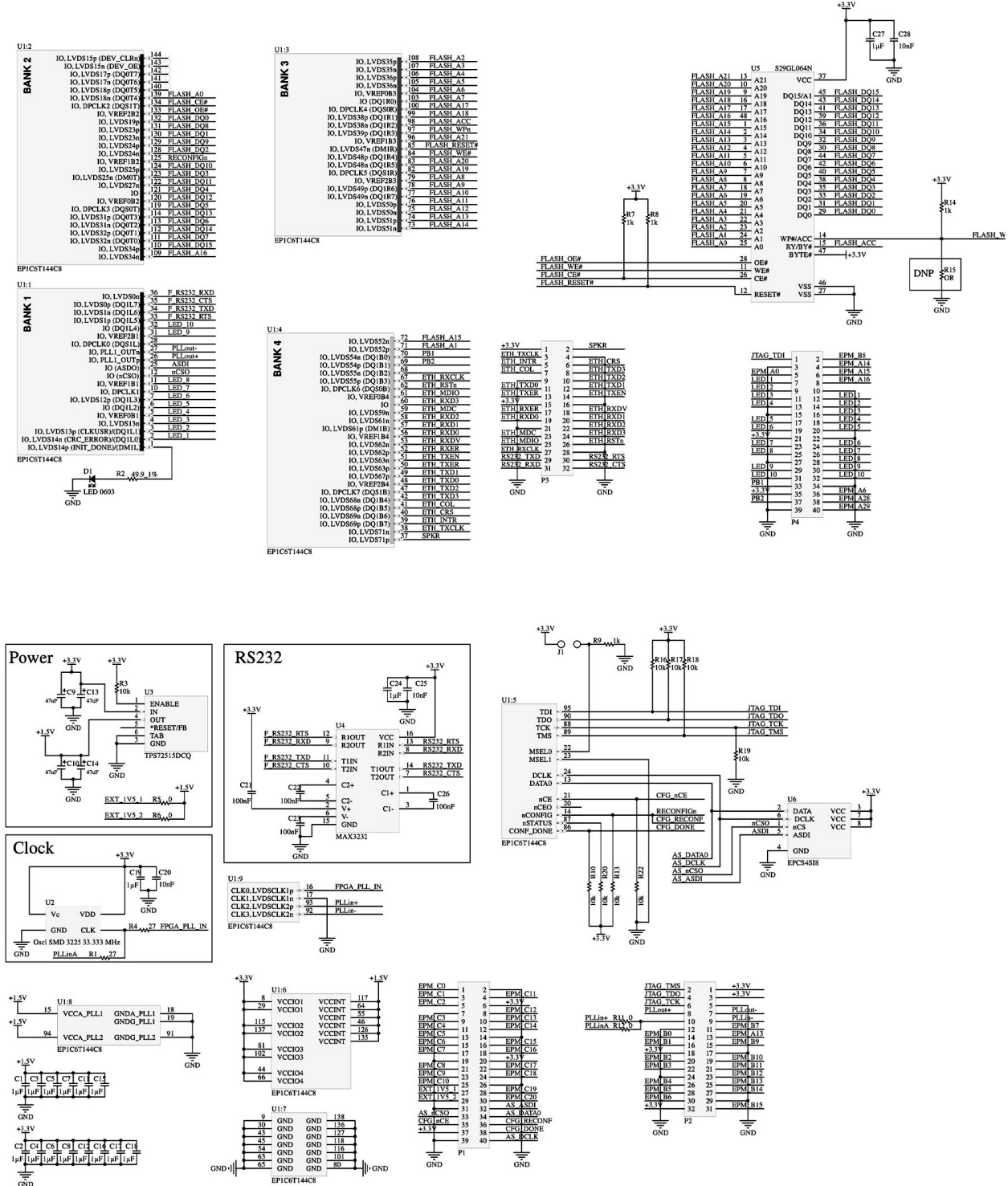

Fig. 5. Circuit diagram of a digital control system for pulsed NQR spectrometer

D. Practical implementation and experiment

The device PCB (Fig. 6) was developed in the Altium Designer software environment. This made it possible to calculate the geometry of the board (external dimensions and shape) and optimize the location of electronic components. For tracing the board, highly efficient algorithms are used, for example, ActiveRoute. The topology of the board is made using 2 layers and double-sided mounting of SMD components. The board is shielded on both sides with grounded polygons. The dimensions of the board are 51 mm × 51 mm, while the width of the signal wires is 0.2 mm, and the width of the power rails is 0.5 mm.

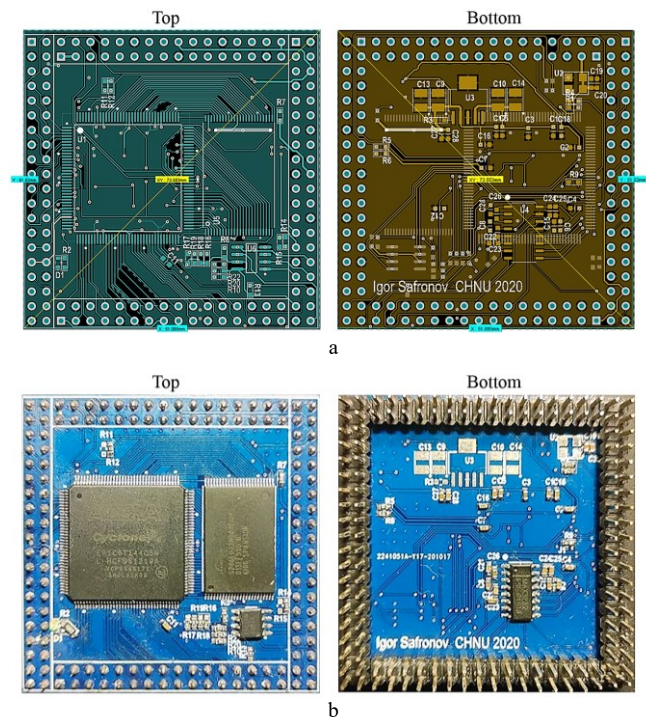

Fig. 6. Topology of the printed circuit board of the digital control system of the pulsed NQR spectrometer: a – PCB; b – device photo.

The algorithm of the software part of the proposed system is considered in [5]. The initial stage is the initialization of the I/O devices, polling the temperature sensor, reading the settings from external memory and subsequent writing the initial data to the memory registers. In this case, the spectrometer control system provides the display of the main parameters on the display and their output to the 4-bit interface bus, which provides data transmission to the spectrometer executing devices at a speed of at least 3 Mbit/s. Thus, the transmission of the parameter settings to the motherboard is realized, and then to the digital frequency synthesizer, the device for generating radio pulses, the sequence programmer, the transceiver, controlled filters and other functional units of the spectrometer.

The proposed device is used in the complex of the equipment of a pulsed coherent NQR spectrometer, where the final debugging of the microprogram takes place (Fig. 7).

IV. CONCLUSIONS

Programmable logic integrated circuits provide ample opportunities for configuring electronic devices, both at the design stage and after manufacture. Rapid configuration, especially at the stage of equipment manufacturing, allows differentiating the final electronic circuit, while reducing costs

and project risks, which significantly accelerates the time to market for a product. Modern static-configured FPGAs offer many additional features, including embedded microprocessors (SoC-FPGA chip systems), memory modules, digital signal processors, high-speed interfaces, and other important functional units.

A digital multifunctional control system for pulse coherent Fourier NQR spectrometer of laboratory type has been developed, the main hardware and software methods of which are implemented using FPGA with static configuration EP1C6T144C8N. The test results of the device showed that its functionality meets all the standards for this class of relaxation and pulse-resonance spectroscopy equipment.



Fig. 7. Graphical interface of the control system of the radio spectrometer: a – user interface screen, b – menu entry, c – synthesizer settings, d – choice of technique, e – setup the RF path, f – dynamic screen saver.

REFERENCES

- [1] Z. D. Kovalyuk, G. I. Lastivka, A. G. Khandozhko, "Fine structure of NQR Spectra in GaSe," Semiconductor physics, Quantum electronics and Optoelectronics, vol. 12, pp. 370–374, 2009.
- [2] T. M. Buzug, S. Kaufmann, R. Marquina-Sanchez, M. Ryschka, and T. F. Sattel, "A Control Unit for a Magnetic Particle Spectrometer," Springer Proceedings in Physics Magnetic Particle Imaging, vol.140, pp. 309–312, 2012.
- [3] A. H. G. AL-Dhaher, "Development of Microcontroller / FPGA-based systems," Int. J. Engng Ed., vol. 20(1), pp. 52–60, 2004.
- [4] Cyclone Device Handbook," 7 June 2008 https://www.altera.com/content/dam/altera-www/global/en_US/pdfs/literature/hb/cyc/cyclone_device_handbook.pdf, 15 October 2016.
- [5] A. Samila, O. Hotra, L. Politansky, and S.Khrapko, "Application of a statically configured FPGA in the digital control system of the NQR radio spectrometer," Proceedings of SPIE 10808 : Photonics Applications in Astronomy, Communications, Industry, and High-Energy Physics Experiments, Poland, Wilga, pp. 108081K-1–108081K-9, 2018.